



Hydro One

H₂O Under Counter Drinking Water Filter

User Operation & Maintenance Manual

(Version Dec 2005)

Hydro One Resources Sdn. Bhd.

68, Jalan 1 / 2, Rawang Integrated Industrial Park, 48000, Rawang, MALAYSIA
Tel: 603-60920120 Fax: 603-60920305 Email: enquiry@hydro1.com.my
(Company No. 605155-X)

H₂O Under Counter Drinking Water Filter

1. Product Features at a Glance...

- Membrane filtration performance at 0.01 microns to filter out all form of particle sediments, chemical such as chlorine, harmful organics and bacteria
- Apply 5 stages of filtration cartridges
- Low pressure requirements & low pressure drop
- Membrane cartridge is backwash-able and long in life span
- No electricity & pump is required for operation
- Convenience and direct drinkable
- Maintain natural mineral & good taste of water

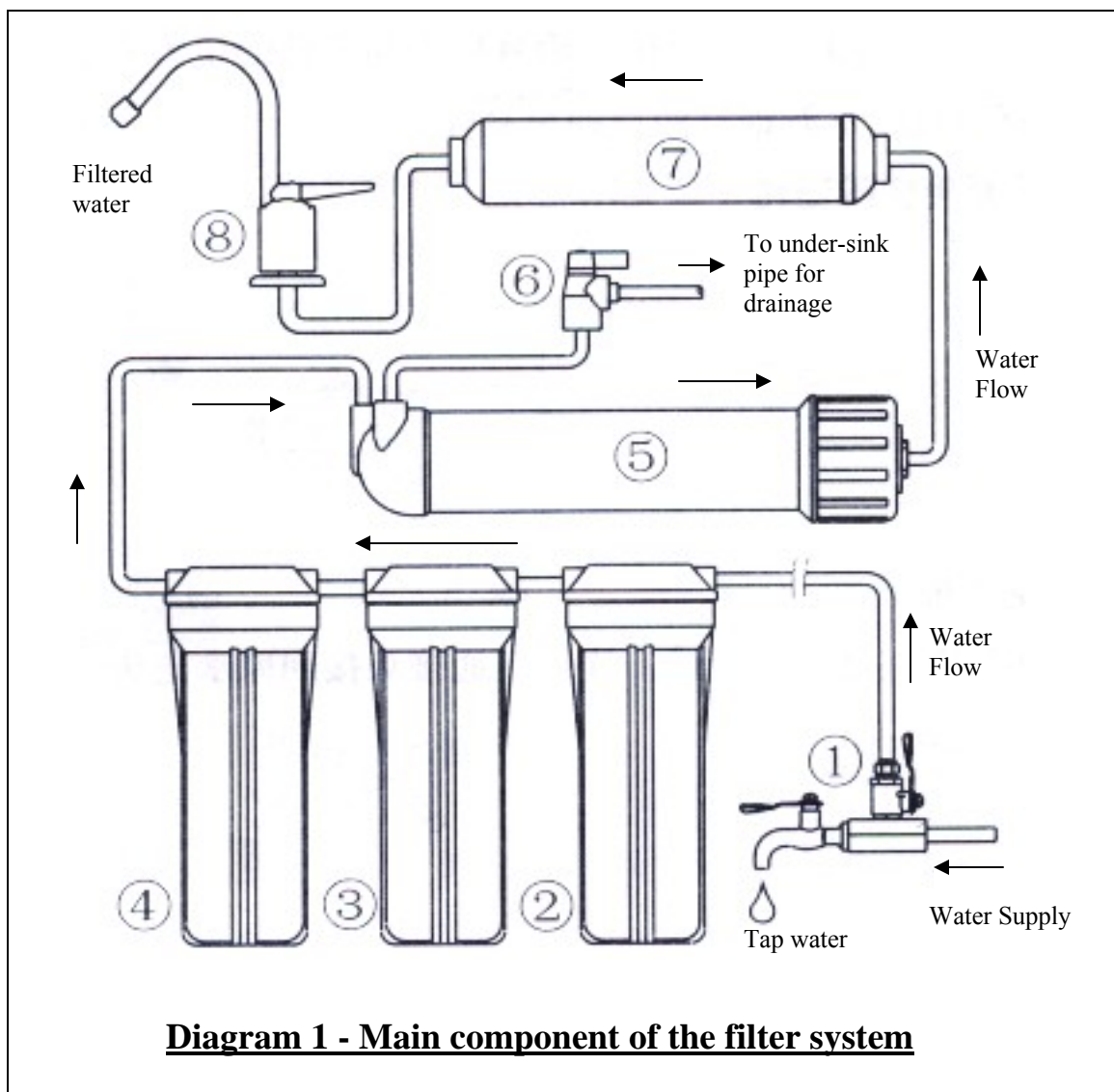

2. Parts Identification - Main component of the filter system:

1. T-join between Water Tap & Ball Valve to filter's Inlet (3/8" water tube)
2. Pre-filter (PP cartridge)
3. Activated Carbon Block Cartridge
4. Granular Activated Carbon Cartridge
5. H₂O Membrane Cartridge
6. Backwash Valve
7. Taste & Odour Removal Cartridge
8. Filter's Outlet (2/8" water tube) connected to faucet water tap

Functions of parts/ components...

- **Inlet Ball Valve**

City Water supply comes into the connected T-join (Part No. 1 in Diagram 1) for user to choose either direct tap water or filtered water. Close Inlet Ball Valve will stop water flow into the filter to prevent over-pressurised. (Refer 'Section 6 – Precautions & Maintenance')

- **Backwash Valve**

For maintenance of the H₂O Membrane Cartridge (Part No. 5 in Diagram 1) by flushing out water with contaminant. Flushing is performed by turning on the “normally-closed” ball valve (Part No. 6 in Diagram 1) on periodical basis. (Refer 'Section 5 - Operation').

- **Cartridge Level 1 – Pre-filter** (Part No. 2 in Diagram 1)

To filter out sediments up to 5 microns of mud, rust, sludge from in coming city water for further filtration process. The cartridge of the filter can be removed for cleansing. Life span **9-12 months**.

- **Cartridge Level 2 –Activated Carbon Block** (Part No. 3 in Diagram 1)

To absorb the colour, odour, residual chlorine & other organic matters for post-treatment of filtration. Life span **4-10 months**.

- **Cartridge Level 3 – Granular Activated Carbon** (Part No. 4 in Diagram 1)

Further intensive treatment & absorption on colour, odour, chemicals, residual chlorine & harmful organic matters in water to improve taste of drinking water. Life span **4-10 months**.

- **Cartridge Level 4 – H₂O Membrane** (part No. 5 in Diagram 1)

Fine filtration that removes 99.9% of bacteria, viruses, harmful micro-organism & other suspended solids within water. Life span **12-16 months**.

- **Cartridge Level 5 – Anti-bacterial Filter**

To maintain the purity of filtered water from Level 4 & prevent chances of second contamination and act as post-production. Life span **9-12 months**.

3. Product Specifications:

- Operation water pressure: 150 kPa ~ 300 kPa (20 psi ~ 40 psi)
- Product (filtered water) flow-rate: 1 liter/ min @ 200 kPa pressure
- Operate at Room Temperature: 5 ~ 40°C
- Pre-filter cartridge* total product volume: 3,000 liter
- H₂O Membrane cartridge* total product volume: 10,000 liter

* can be dismantled from casing to wash & rinse for repeatedly usage.

4. Installation:

The filter is suitable to be installed either under kitchen sink or wall mounted. Refer to the mounting hole at the filter's steel bracket and drilling for M6 screw size.

Assembly of Inlet Ball Valve...

Refer to Diagram 2 for assembly of Inlet Ball Valve to form T-join at the existing Water Tap. Unscrew the existing water tap and screw in the stainless steel connector with thread connection and screw in the Inlet Ball Valve at side as shown.

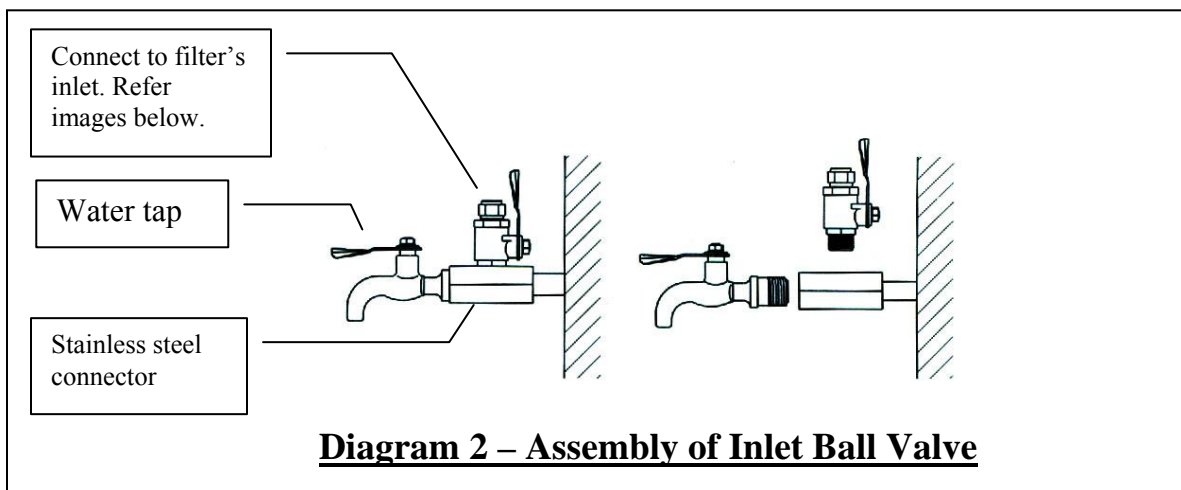

Insert the Inlet water-tube into the ball valve that connected to the stainless steel connector

Installation of faucet water tap...

Refer to Diagram 3 to assemble faucet tap fittings. The faucet tap could be wall mounting as shown in Diagram 3-1 or drill on the faucet/ kitchen sink and mount on it as shown in Diagram 3-2 (Refer Image A).

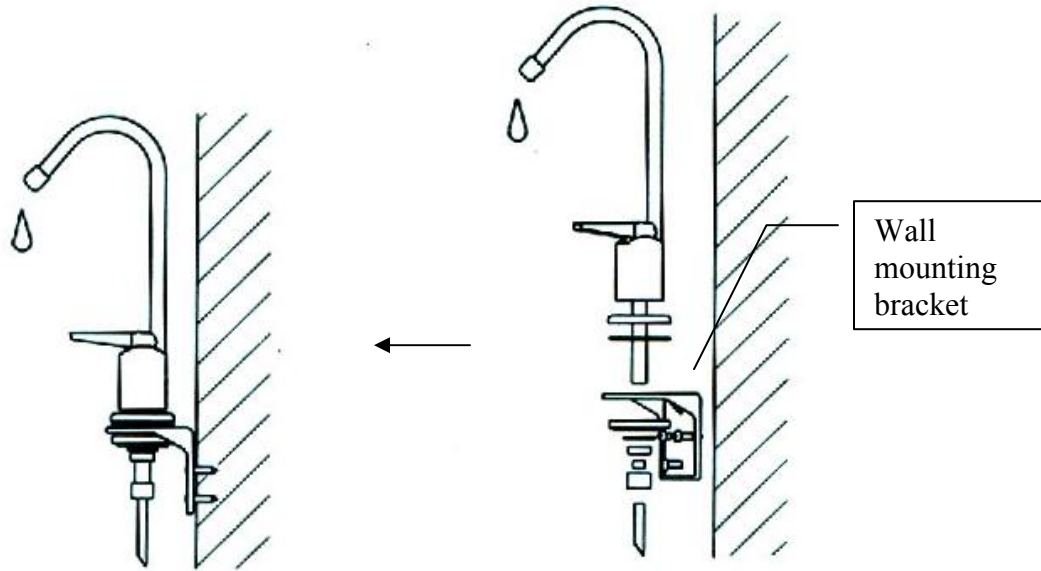

Diagram 3-1 faucet Tap with wall Mounting arrangement

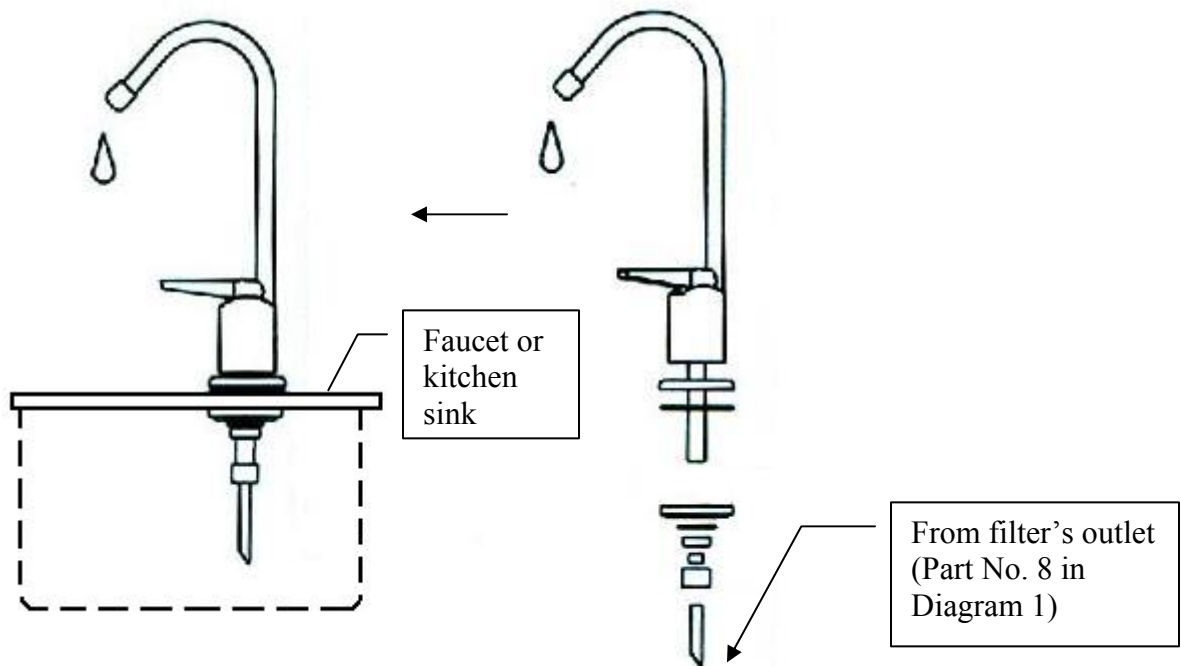
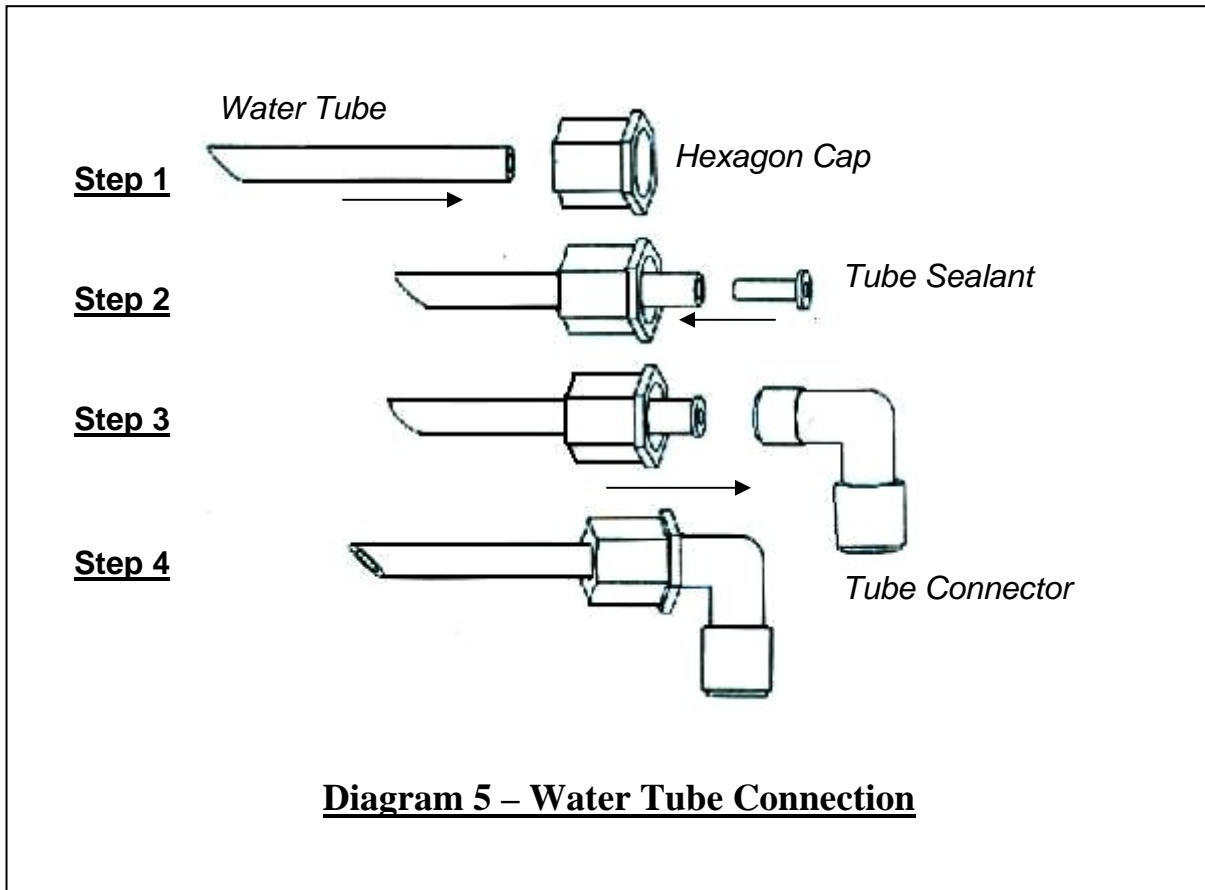

Diagram 3-2 faucet Tap with kitchen sink mounting arrangement

Connection of Water Tube...



Refer to the steps shown above to establish a firm connection between a water tube and cartridge casing's port or ball valve.

Connect first water tube with one end to the Inlet Valve (Part No. 1 in Diagram 1) and the other end to the 'In' Port of Cartridge Level 1 (Part No. 2 in Diagram 1).

Connect second water tube with one end to the 'Out' Port of the Cartridge Level 5 (Part No. 7 in Diagram 1) and the other end connected to the faucet tap.

Connect the third water tube with one end from the H₂O Membrane Cartridge Casing's waste port and the other end to the Backwash Ball Valve (Refer Diagram 4).

Connect the fourth tube with one end from the Backwash Ball Valve and another end either penetrated to the sink pipe or rolled up for discharge later.



Image A – Faucet Tap installed at Kitchen sink



Backwash Ball valve

Waste tube being rolled up and only released out for discharge whenever needed, without penetrated to the sink pipe.

Image B – Installed Unit under sink

5. Operation:

For first time usage after installation, kindly follow the following procedures:

- *Open the filter's Inlet Valve and water tap to let water supply flow through the system.*
- *When water is starting to flow out from the water tap, close the tap.*
- *Wait after 20 minutes, open the filter's water tap again.*
- *Let water flow through 5 minutes or longer time until the water is odorless.*
- *Close the water tap and it is ready to use.*

During normal operation, open the faucet tap and let water flow out a while then contain the water directly and consume.

6. Precautions & Maintenance:

To achieve optimum drinking water quality, the following procedures should be taken note:

- *During the first usage of the day, filter's water tap should be opened to let water flow through for approximately 1min. and then close the tap. Open the tap again and after about 500ml of water is flowed out, then only drink direct from the water of the filter's tap.*
- *After the last usage of the day, kindly close the filter's Inlet Valve and switch back to direct water supply. This will prevent "water hammering", a situation where water supply pressure fluctuation that may damage the filter system.*

The following maintenance is advised to carry out frequently to achieve optimum drinking water quality.

- *Cartridge Level 1 & 4 can be removed out from its casing and washed manually to maintain the hygienic level of the cartridge. This is advisable to repeat every 3 months after operation.*
- *Periodically open the Backwash Valve (Part No. 6 in Diagram 1) to flush out the waste water, advisable on weekly for about 1-3 minutes.*
- *If filtered water is not consumed, kindly close the filter's Inlet Valve to prevent internal water hammering pressure within the system.*
- *If system is not used for long time, kindly repeat steps in '5. Operation'.*
- *When tightening the cartridge casing, kindly take good care on the rubber O-Ring to prevent serious wear-&-tear situation.*
- *Always consider to replace the cartridges after long time of operation to maintain the system at highest hygienic level. Kindly refer to '2. Main Components of the System' above.*